

VETUS[®]

*Operation manual
and
installation instructions*

Solar charger

SL45

SL60



Contents

1	Description	4	3	Front Cover Operation	26
1.1	Versions and Ratings	5	3.1	LED Status Indicators	26
1.2	Operating Modes	5	3.2	Charge Control or Diversion Control Mode Indications	27
1.3	Adjustability	6	3.3	Load Control Indicators	27
1.4	General Use	7	3.4	Equalization Mode Indication	28
1.5	Optional Available	8	3.5	Fault Mode Indication	29
2	Installation	9	3.6	LCD Meter Display	29
2.1	General Information	9	3.6.1	LCD Displays Flow	30
2.2	Installation Overview	9	3.6.2	Fault Messages	31
2.3	Control Terminal Connection	10	4	Solar Battery Charging	32
2.4	Installation Steps	13	4.1	PWM Battery Charging	32
2.4.1	Mounting	14	4.1.1	Four Stages of Solar Charging	32
2.4.2	Solar Battery Charging DIP Switch Settings	15	4.1.2	Battery Charging Notes	33
2.4.3	Load Control DIP Switch Setting	18	4.2	Standard Battery Charging Pro- grams	34
2.4.4	Diversion Charge Control DIP Switch Setting	20	4.3	Temperature Effects	35
2.4.5	Battery Temperature Sensor (BTS)	20	4.3.1	Battery Temperature Sensor (BTS)	35
2.4.6	System Wiring and Power-Up	21	4.4	Equalization	36
2.4.7	Finish Installation	23	4.4.1	Standard Equalization Programs	37
2.5	Communication with the Vetus Combi-Gamma	24	4.4.2	Typical Equalizations	38
			4.4.3	When to Equalize	38
			4.5	Float	38

5	Load Control	39	8.4	Nicad and NiFe Batteries	52
5.1	Inductive Loads (Motors)	39			
5.2	General Load Control Notes	40			
5.2.1	Inverters	40			
5.2.2	Parallel Vetus Solar Chargers	40			
5.2.3	Reverse Polarity	40			
6	Diversion Charge Control	42			
6.1	Diversion Charge Control	42			
6.2	Diversion Current Ratings	42			
6.3	Standard Diversion Battery Charging Programs	43			
6.4	Selecting the Diversion Load	44			
6.4.1	Suitable Loads for Diversion.	44			
6.4.2	Definition of Terms	44			
6.4.3	Load Power Ratings	45			
6.4.4	Maximum Diversion Load	45			
6.4.5	Minimum Diversion Load	46			
7	Trouble Shooting	48			
8	Battery Information	50			
8.1	Sealed Batteries	50			
8.2	Flooded Batteries	51			
8.3	L-16 Cells	52			

1 Description

The Vetus Solar Charger SL is a technically advanced solar system controller. There are three operating modes programmed into each Vetus Solar Charger SL. The manual describes solar battery charging, DC diversion charge control or DC Load control instructions are inserted where required.

The manual will help you to become familiar with the Vetus Solar Charger SL's features and capabilities. This operation manual is applicable to the software version V1.05 and later version of the Vetus Solar Charger SL units. Some of these follow:

- Solid-state Pulse Width Modulated (PWM) charging process with four-stage control, temperature compensation, and manual or automatic equalization to maximize system performance and increase battery life.
- Electric overload and short circuit protection with automatic and manual reset capability increase the reliability of unattended systems by eliminating blown fuses and tripped circuit breakers.
- Optional external battery temperature compensation (BTS) for automatic adjustment of charge set points.
- Over-temperature protection for the electronic circuitry when used in hot environment (over 80°)
- LCD meter with easy to read mode/status messages.
- An 8-position DIP switch to set up the controller for its intended use. All major functions can be set with DIP switches.
- Rated for 12, 24, 48 volt systems, and 45 or 60 amps current.
- Eight standard charging or Load programs selected with DIP switches.
- Continuous self-testing with fault notification.
- LED indications and push button functions.
- Complies with EMC and LVD standards for CE marking.

1.1 Versions and Ratings

There are two standard versions of Vetus Solar Charger SL controllers:

SL60: Rated for maximum 60 amps continuous current (solar, load or diversion load)

Rated for 12, 24, 48 V DC systems

SL45: Rated for maximum 45 amps continuous current (solar, load or diversion load)

Rated for 12, 24, 48 V DC systems

1.2 Operating Modes

There are three distinct and independent operating modes programmed into each Vetus Solar Charger SL. Only one mode of operation can be selected for an individual Vetus Solar Charger SL. If a system requires a charging controller and a load controller, two Vetus Solar Charger SLs must be used.

Solar Battery Charging

The energy output of a solar array is used for recharging the system battery.

The Vetus Solar Charger SL manages the charging process to be efficient and to maximize the life of the battery. Charging includes a bulk charging stage, PWM absorption, float and equalization.

DC Load Control

When set for DC load control, the Vetus Solar Charger SL powers loads from the battery, and protects the battery from over-discharge with a current compensated LVD (low voltage load disconnect).

DC Diversion Charge Control

In DC diversion mode, the Vetus Solar Charger SL will manage battery charging by diverting energy from the battery to a dedicated diversion load. The energy source is typically wind or hydro.

1.3 Adjustability

Eight DIP switches permit the following parameters to be adjusted at the installation site:

DIP switch	Solar battery charging (Diversion charge control)
1 (OFF)	Battery charge control mode (Diversion charge control mode)

2	3	Select Battery Voltage
OFF	OFF	48V system
ON	OFF	24V system
OFF	ON	12V system

4~6	Standard battery charging programs	
7 (OFF)	Manual Equalization	
(ON)	Auto Equalization	
8 (OFF)	Operating from Dip Switch 4~6 battery charging programs settings	
(ON)	VR1 and VR2 settings for user define battery charging programs	

DIP switch	Load control
1 (ON)	Load control mode

2	3	Select Battery Voltage
OFF	OFF	48V system
ON	OFF	24V system
OFF	ON	12V system

DIP switch	Load control
4~6	Standard low voltage disconnects and reconnects
7 (OFF)	Manual reconnect for Dip Switch 4~6 standard low voltage
(ON)	Auto reconnect for Dip Switch 4~6 standard low voltage
8 (OFF)	Operating from Dip Switch 4~6 standard low voltage disconnects and reconnects
(ON)	VR1 and VR2 settings for user define low voltage disconnects and reconnects

1.4 General Use

NOTE:

This manual describes solar battery charging. Specific instructions for the DC load control and DC diversion charge control modes are provided as notes throughout this manual.

- The Vetus Solar Charger is suitable for a wide range of solar applications including homes, telecom and industrial power needs.
- The Vetus Solar Charger controllers are configured for negative ground systems. There are no parts in the controller's negative leg. The enclosure can be grounded using the ground terminal in the wiring compartment.
- The Vetus Solar Charger is protected from faults electronically with automatic recovery. There are no fuses or mechanical parts inside the Vetus Solar Charger SL to reset or change.
- Solar overloads up to 130% of rated current will be tapered down instead of disconnecting the solar. Over-temperature conditions will also taper the solar input to lower levels to avoid a disconnect.
- Any number of Vetus Solar Chargers can be connected in parallel to increase solar charging current. Vetus Solar Chargers can be paralleled ONLY in the battery charging mode. DO NOT parallel Vetus Solar Chargers in the load mode, as this can damage the controller or load.
- The Vetus Solar Charger is rated for indoor use. The controller is protected by conformal coated circuit boards, stainless steel hardware, anodized aluminium, and a powder coated enclosure, but it is not rated for corrosive environments or water entry.
- The construction of the Vetus Solar Charger is 100% solid state.
- Battery charging is by a series PWM constant current charging, with bulk charging, PWM absorption, float and equalization stages.
- The Vetus Solar Charger will accurately measure time over long intervals to manage events such as automatic equalizations or battery service notification.
- Day and night conditions are detected by the Vetus Solar Charger, and no blocking diodes are used in the power path.
- LED's, a push button, and LCD meters provide both status information and various manual operations.

1.5 Optional Available

Three optional components can be added to the standard Vetus Solar Charger controller at any time.

Battery Temperature Sensor (BTS)

If the temperature of the system battery varies more than 5°C during the year, temperature compensated charging should be considered. Because the battery's chemical reactions change with temperature, it can be important to adjust charging to account for the temperature effects. The BTS will measure the battery temperature, and the Vetus Solar Charger uses this input to adjust the charging as required.

The battery charging will be corrected for temperature as follows:

Charger Set point Temperature Compensation Chart

Battery Type	System Voltage		
	12VDC	24VDC	48VDC
Lead Acid	-30mV/°C	-60mV/°C	-120mV/°C
Nicad	-20mV/°C	-40mV/°C	-80mV/°C

The BTS should be used only for battery charging and diversion control. Do not use the BTS for load control. The charging parameters that are adjusted for temperature include:

- PWM regulation
- Equalization
- Float
- High Voltage Disconnect

RJ-45 Communication Cable

RJ-45 Communication Cable is used to connect the Vetus Solar Chargers to the Vetus Combi-Gamma Inverter/Charger. The connection of the Vetus Combi-Gamma and Vetus Solar Chargers can become a power management control system of standalone PV charger. When connecting a Vetus Combi-Gamma to Vetus Solar Chargers in parallel, the maximum units can go up to 10 Vetus Solar Chargers. The optional RJ-45 Communication Cables can be supplied in the following length.

- RJ-45-03 (3 Meter long Communication Cable)
- RJ-45-05 (5 Meter long Communication Cable)
- RJ-45-10 (10 Meter long Communication Cable)

2 Installation

The installation instructions describe solar battery charging. Specific instructions for the load control and diversion modes are provided as notes.

2.1 General Information

The mounting location is important to the performance and operating life of the controller. The environment must be dry and protected as noted below. The controller may be installed in a ventilated enclosure with sealed batteries, but never in a sealed battery enclosure or with vented batteries.

If the solar array exceeds the current rating of the controller, multiple Vetus Solar Chargers can be installed in parallel. Additional parallel controllers can also be added in the future. The load controllers cannot be used in parallel.

If solar charging and load control are both required, two separate controllers must be used.

2.2 Installation Overview

The installation is straightforward, but it is important that each step is done correctly and safely. A mistake can lead to dangerous voltage and current levels. Be sure to carefully follow each instruction in Section 2.3 and observe all cautions and warnings.

The following diagrams provide an overview of the connections and the proper order:

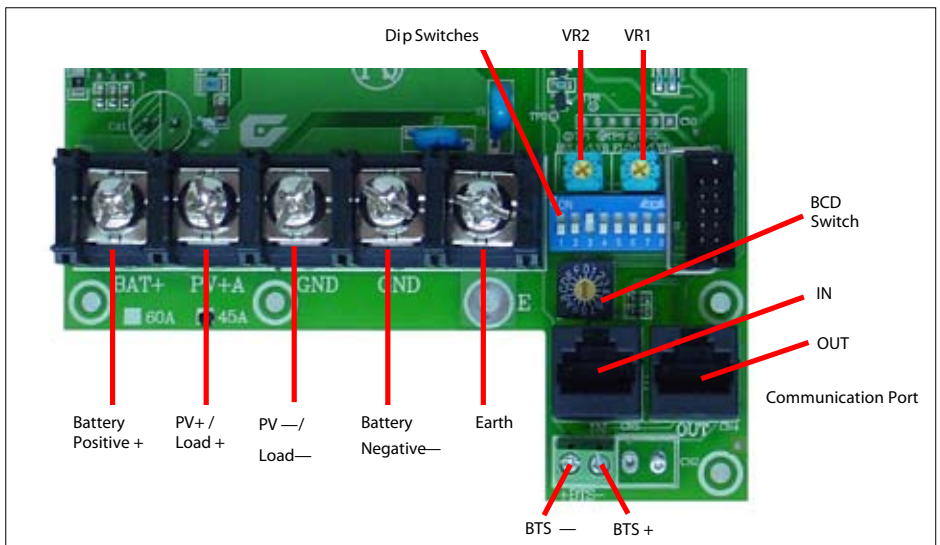

2.3 Control Terminal Connection

Name	Description
Battery +	Battery cable Positive connection
PV+ / Load +	Connecting terminal for Solar Array or DC Load Positive
PV—/Load—	Connecting terminal for Solar Array or DC Load Negative
Battery—	Battery cable Negative connection
Earth	Connecting terminal for Ground
Dip Switch 1	ON or OFF to choose battery charge control mode or load control mode
Dip Switch 2, 3	Selection of battery voltage for 12V or 24V or 48V system
Dip Switch 4, 5, 6	Battery charge control mode: Battery charging algorithm
	Load control mode: Load control disconnect/reconnect algorithm
Dip Switch 7	Battery charge control mode: Auto / Manual Equalization
	Load control mode: Auto / Manual Reconnect
Dip Switch 8	ON: Potentiometer of VR1, VR2 setting range
	OFF: Dip switch 4~6 setting range
VR1, VR2	User define battery charging programs or user define standard low voltage disconnect and reconnect
BCD Switch 0	Vetus Solar Charger unit is operating alone.
	*When the BCD Switch is not placed at 0 and the fault message of " Alarm: CPF01 Wait for Combi" will be displayed if the Vetus Solar Charger unit is not communicating with Vetus Combi-Gamma
BCD 1~A	1st~10th Vetus Solar Charger units are communicating with Vetus Combi-Gamma
BCD B~F	They are operating as the 10th Vetus Solar Charger unit
Communication IN	Communication port for Vetus Combi-Gamma
Communication OUT	Communication port for the next Vetus Solar Charger unit
BTS+	Connecting terminal for Battery Temperature Sensor Positive
BTS—	Connecting terminal for Battery Temperature Sensor Negative

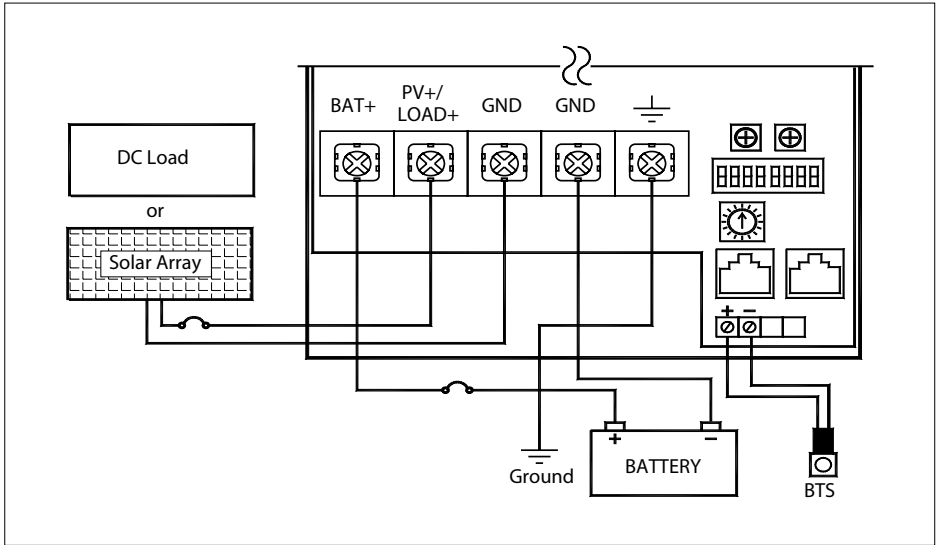

Installation wiring for solar charging or DC load control

Solar charging or DC load control:

Step 1: Open the access cover

Step 2: Mount the Vetus Solar Charger using the enclosed template.

Step 3: Adjust the 8 switches in the DIP switch. Each switch must be in the correct position.

Step 4: Attach the BTS if battery charging will be temperature compensated (not for load control).

Step 5: Connect the battery power wires to the Vetus Solar Charger. Then connect the solar array wires (or DC load wires).

Step 6: Close the cover.

Step 4 is optional.

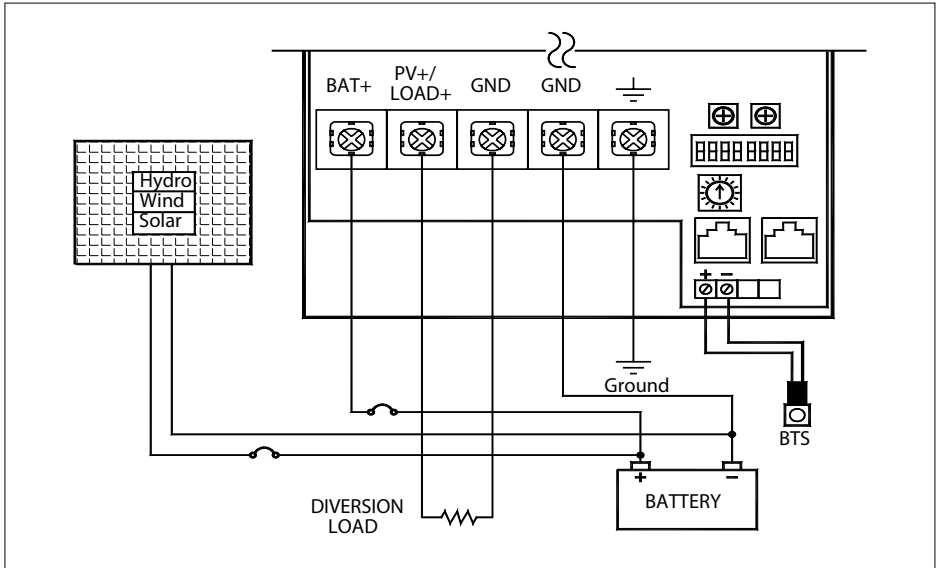

Installation wiring for DC diversion charge control

DC diversion charge control:

Step 1: Open the access cover

Step 2: Mount the Vetus Solar Charger using the enclosed template.

Step 3: Adjust the 8 switches in the DIP switch. Each switch must be in the correct position.

Step 4: Attach the BTS if battery charging will be temperature compensated

Step 5: Connect the battery power wires to the Vetus Solar Charger. Then connect the diversion load wires.

Step 6: Close the cover.

Step 4 is optional.

2.4 Installation Steps

The Vetus Solar Charger controller must be installed properly and in accordance with the local and national electrical codes. It is also important that the installation be done safely, correctly and completely to realize all the benefits that the Vetus Solar Charger can provide for your solar system.

Before starting the installation, review these safety notes:

- Do not exceed a battery voltage of 48V (nominal). Do not use a battery less than 12V.
- Do not connect a solar input greater than a nominal 48V array for battery charging. Never exceed a VOC (open-circuit voltage) of 140V.
- Charge only 12, 24, or 48 volt lead-acid batteries when using the standard battery charging programs or NI-CAD batteries when DIP switch number 4~6 is ON position in the Vetus Solar Charger.
- Verify the nominal charging voltage is the same as the nominal battery voltage.
- Do not install a Vetus Solar Charger in a sealed compartment with batteries.
- Never open the Vetus Solar Charger access cover unless both the solar and battery power has been disconnected.
- Never allow the solar array to be connected to the Vetus Solar Charger with the battery disconnected. This can be a dangerous condition with high open-circuit solar voltages present at the terminals.

2.4.1 Mounting

Unit: mm (inches)

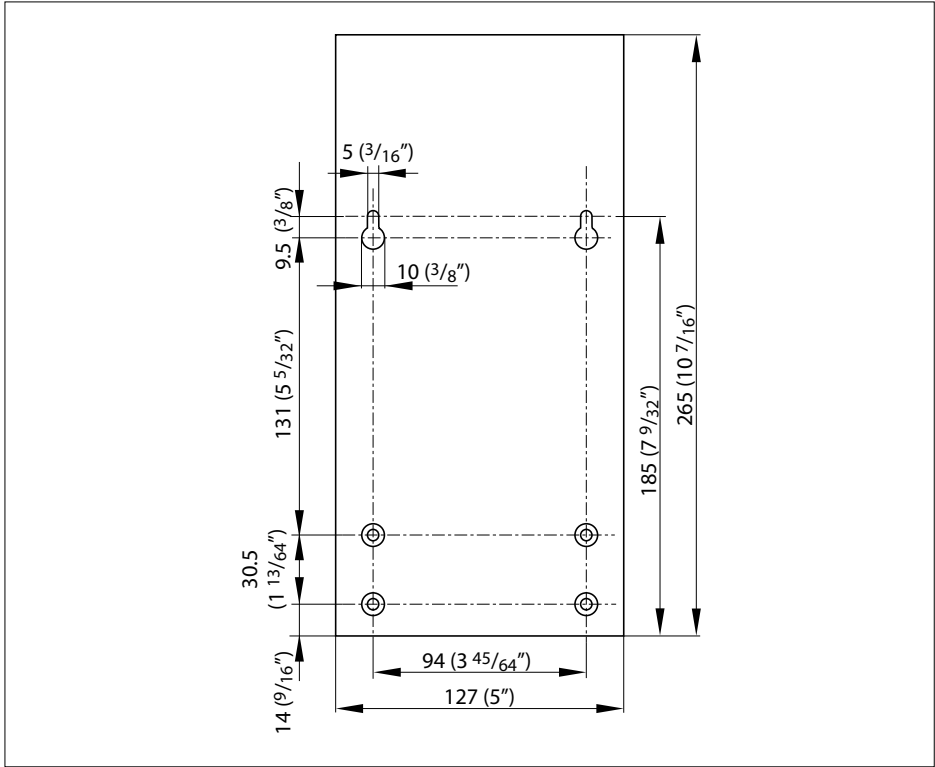

Mounting Dimensions

- Locate the Vetus Solar Charger on a wall protected from direct sun, high temperatures, and water. Do not install in a confined area where battery gasses can accumulate.
- When mounting the Vetus Solar Charger, make sure the air flow around the controller and heat sink is not obstructed. There should be open space above and below the heat sink, and at least 75 mm (3 inches) clearance around the heat sink to allow free air flow for cooling.
- Before starting the installation, place the Vetus Solar Charger on the wall where it will be mounted and determine where the wires will enter the controller.

2.4.2 Solar Battery Charging DIP Switch Settings

The 8 DIP switches are located on the right of the Earth terminal. Each switch is numbered. The solar battery charging functions that can be adjusted with the DIP switches follow:

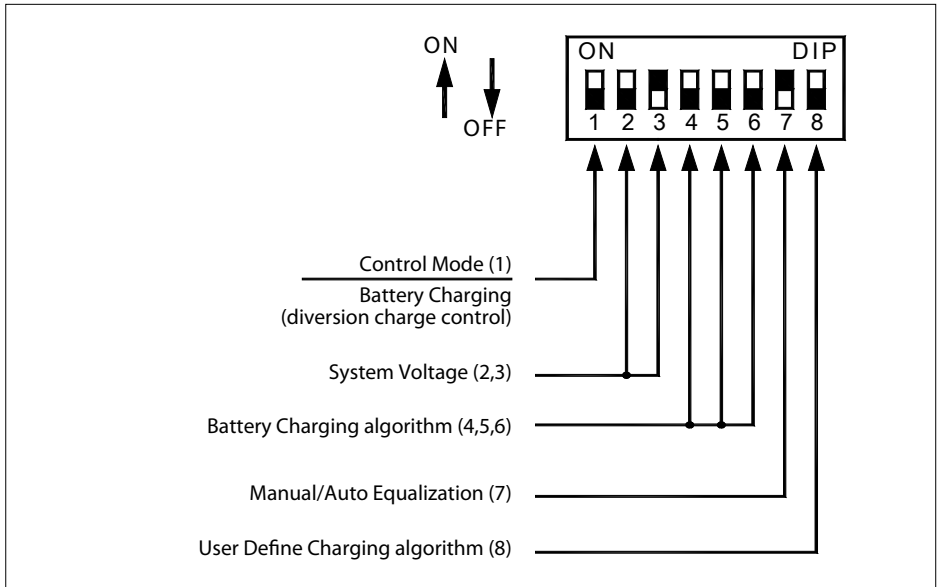

DIP Switch Functions

As shown in the diagram, all the positions are in the "OFF" position except switch number 3 and 7 which are in the "ON" position.

NOTE: The DIP switches should be changed only when there is no power to the controller. Turn off disconnect switches and remove all power to the controller before changing a DIP switch. A fault will be indicated if a switch is changed while the controller is powered.

CAUTION 1: The Vetus Solar Charger is shipped with all the switches in the "OFF" position. Each switch position must be confirmed during installation. A wrong setting could cause damage to the battery or other system components.

CAUTION 2: To configure your Vetus Solar Charger for the battery charging and control you require, follow the DIP switch adjustments described below. Before changing any switch, make sure the BCD switch is placed at number 0 for the Vetus Solar Charger settings. To change a switch from OFF to ON, slide the switch up towards the top of the controller. Make sure each switch is fully in the ON or OFF position.

DIP Switch Number 1-Control Mode: Solar battery charging

Switch 1	Control Mode
ON	Load control mode
OFF	Solar charging mode (Diversion charge control mode)

For the solar battery charging control mode, leave the DIP switch in the OFF position.

DIP Switch Number 2, 3-System voltage

Switch 2	Switch 3	System Voltage
OFF	OFF	48V system
ON	OFF	24V system
OFF	ON	12V system

DIP Switch Number 4, 5, 6-Battery charging algorithm

DIPSW-4	DIP SW-5	DIP SW-6	Bulk voltage	Float voltage	Equalize Voltage	Equalize Time (hours)	Equalize Interval (days)
OFF	OFF	OFF	14.0V	13.4V	None	-	-
OFF	OFF	ON	14.1V	13.4V	14.2V	1	28
OFF	ON	OFF	14.3V	13.4V	14.4V	2	28
OFF	ON	ON	14.4V	13.4V	15.1V	3	28
ON	OFF	OFF	14.6V	13.4V	15.3V	3	28
ON	OFF	ON	14.8V	13.4V	15.3V	3	28
ON	ON	OFF	15.0V	13.4V	15.3V	3	14
ON	ON	ON	16.0V	14.5V	-	-	-

Select one of the 7 standard battery charging algorithms, or select NiCad to determine the charging of the battery.

- The above setting voltage value is in the condition of 12V system. The voltage will be twice of above values in the 24V system and it will be four times of above values in the 48V system.
- Refer to section 8.0 of the manual for battery charging information.
- The 7 standard charging algorithms above are described in section 4.2-standard battery charging programs.

DIP switch number 7- Battery Equalization

Switch 7	Battery Equalization
ON	Auto Equalization
OFF	Manual Equalization

- In the Auto Equalization Mode (Switch number 7 ON), the Vetus Solar Charger controller can automatically triggering of the equalization process. When automatic has been selected, an equalization charge will occur at set voltage and time (hours and days).

During the equalization process, the status LED indicates equalization (Equalization is not recommended for NiCad batteries and is disabled). The equalization process will continue until the voltage has been held above the bulk setting for a cumulative period of set hours as shown above. This might take several days on larger system with big batteries and small solar arrays. The battery voltage only needs to exceed the bulk setting for the timer to start counting-the voltage may not reach the equalization voltage setting. To manually stop the equalization process, press the reset push button and the status LED will stop, if the equalization process was shorter than one hour, the controller will continue with a bulk charge cycle and then hold the battery at the bulk setting for one hour (the absorption voltage) before returning to the float setting. Once a manual equalization has been triggered, the period to the next automatic equalization will be restarted.

In the Manual Equalization Mode (Switch number 7 OFF), equalization will occur only when manually started with the push button. The equalization status LED indicator will begin to equalization enabled. The equalization process will continue until the batteries have been held at or above the set Equalize Voltage for set Equalize Time of accumulated time. During the equalization process, the battery voltage will be limited to the set Equalize Voltage setting. Once the battery voltage has been at or above the set Equalize Voltage for a cumulative period of set Equalize Time, the Vetus Solar Charger will return to the float stage of the charge process. To stop the equalization process, press the reset push button, the status LED will stop. If the equalization process was shorter than one hour, the controller will continue with a bulk charge cycle and hold the battery at bulk setting for one hour (the absorption stage) before returning to the float setting.

DIP switch number 8-User define battery select

Switch 8	Charge Control algorithm
ON	User define (VR1, VR2)
OFF	Dip Switch 4~6 selection

The battery voltage setting range of VR2 BULK Voltage potentiometer is 13.0V~15.0V

The battery voltage setting range of VR1 FLOAT Voltage potentiometer is 12.5V~14.5V

- The above setting voltage value is in the condition of 12V system. The voltage will be twice of above values in the 24V system and it will be four times of above values in the 48V system.

The LCD Meter display will show the voltage setting value of VR2 and VR1 and the user can adjust those values directly.

2.4.3 Load Control DIP Switch Setting

The Load Control functions that can be adjusted with the DIP switches follow:

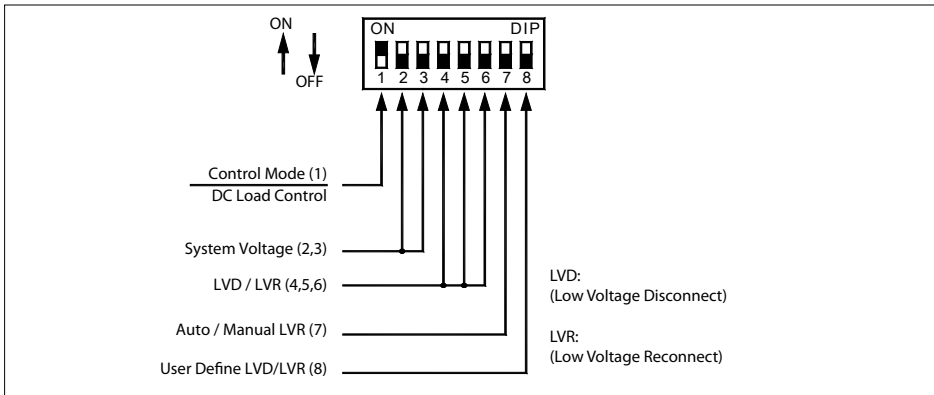

Load Control DIP Switch Functions

- As shown in the diagram, all the positions are in the “OFF” position except switch number 1, which is in the “ON” position.

NOTE: The DIP switches should be changed only when there is no power to the controller. Turn off disconnect switches and remove power to the controller before changing a DIP switch. A fault will be indicated if a switch is changed with the controller powered.

CAUTION 1: The Vetus Solar Charger is shipped with all the switches in the “OFF” position. Each switch position must be confirmed during installation. A wrong setting could cause damage to the load or other system components.

CAUTION 2: To configure your Vetus Solar Charger for the Load Control you require, follow the DIP switch adjustments described below. Before changing any switch, make sure the BCD switch is placed at number 0 for the Vetus Solar Charger settings. To change a switch from OFF to ON, slide the switch up toward the top of the controller. Make sure each switch is fully in the ON or OFF position.

DIP Switch Number 1-Control Mode: Load Control

Switch 1	Control Mode
ON	Load control mode
OFF	Solar charging mode

or the load control mode, move the DIP switch to the ON position.

DIP Switch Number 2, 3-System Voltage

Switch 2	Switch 3	System Voltage
OFF	OFF	48 V system
ON	OFF	24 V system
OFF	ON	12 V system

DIP Switch Number 4, 5, 6-Load Control Algorithm

DIPSW -4	DIP SW-5	DIP SW-6	LVR			LVD		
			12V	24V	48V	12V	24V	48V
OFF	OFF	OFF	12.6V	25.2V	50.4V	11.1V	22.2V	44.4V
OFF	OFF	ON	12.8V	25.6V	51.2V	11.3V	22.6V	45.2V
OFF	ON	OFF	13.0V	26.0V	52.0V	11.5V	23.0V	46.0V
OFF	ON	ON	13.2V	26.4V	52.8V	11.7V	23.4V	46.8V
ON	OFF	OFF	13.4V	26.8V	53.6V	11.9V	23.8V	47.6V
ON	OFF	ON	13.6V	27.2V	54.4V	12.1V	24.2V	48.4V
ON	ON	OFF	13.8V	27.6V	55.8V	12.3V	24.6V	49.2V
ON	ON	ON	12.0V	24.0V	48.0V	10.5V	21.0V	42.0V

Select 1 of the 8 standard load control algorithms.

Dip Switch Number 7-Auto Reconnect or Disconnect standard low voltage

Switch 7	Selection
ON	Auto Reconnect after low voltage returning to Dip Switch 4~6 standard LVR setting
OFF	Manual Reconnect after low voltage disconnect (LVD)

Manual reconnect of the loads is allowed when voltage has not exceeded the LVR setting. To reconnect the loads, press the reset button on the front panel of the unit. If the voltage is below the LVR level, the DC load can be reconnected from approximately 6 minutes. Multiple reconnects are allowed, but the “on” time duration will vary with battery voltage. (Approximately 5 seconds when the battery voltage is under 10V).

When Dip Switch 7 is ON position, it allows the controller to be set for Auto reconnect of the DC load when the voltage exceeds the LVR setting.

DIP switch number 8-User define LVR, LVD

Switch 8	Load Control algorithm
ON	User define (VR1, VR2)
OFF	Dip Switch 4~6 selection

LVR range set by VR2:	12.0V~14.0V (12V system)
	24.0V~28.0V (24V system)
	48.0V~56.0V (48V system)
LVD range set by VR1:	10.5V~12.5V (12V system)
	21.0V~25.0V (24V system)
	42.0V~50.0V (48V system)

The LED Meter display will show the voltage setting value of LVR (VR2) and LVD (VR1) and the user can adjust those values directly.

2.4.4 Diversion Charge Control DIP Switch Setting

Diversion charge control DIP switch settings are exactly the same as solar battery charging DIP switch setting which can be referred to 2.4.2 description.

2.4.5 Battery Temperature Sensor (BTS)

For solar battery charging and diversion load control, a Battery Temperature Sensor (BTS) is recommended for effective temperature compensated charging.

This Battery Temperature Sensor should not be installed for DC load control. The BTS is supplied with 10 meters (33 ft) of 0.34 mm² (22 AWG) cable. There is +/- polarity so pay attention to connecting the polarity. Reverse of the polarity may damage the BTS.

2.4.6 System Wiring and Power-Up

Wire Size:

The five large power terminals are sized for 35 - 2.5 mm² (2-14 AWG) wire. The terminals are rated for copper and aluminium conductors. Good system design generally requires large conductor wires for the solar and battery connections that limit voltage drop losses to 3% or less. The following table provides the maximum wire length (1-way distance / 2-wire pair) or connecting the battery, solar array or load to the Vetus Solar Charger with a maximum 3% voltage drop.

Wire size	60 A	45 A	Wire size	60 A	45 A
95 mm ²	12,86 m	17,15 m	(3/0 AWG)	(42.2 ft.)	(56.3 ft.)
70 mm ²	10,19 m	13,58 m	(2/0 AWG)	(33.4 ft.)	(44.6 ft.)
50 mm ²	8,10 m	10,80 m	(1/0 AWG)	(26.6 ft.)	(35.4 ft.)
35 mm ²	5,12 m	6,83 m	(2 AWG)	(16.8 ft.)	(22.4 ft.)
25 mm ²	3,21 m	4,27 m	(4 AWG)	(10.5 ft.)	(14.0 ft.)
16 mm ²	2,02 m	2,69 m	(6 AWG)	(6.6 ft.)	(8.8 ft.)
10 mm ²	1,27 m	1,70 m	(8 AWG)	(4.2 ft.)	(5.6 ft.)
6 mm ²		1,06 m	(10 AWG)		(3.5 ft.)

Maximum 1-Way Wire Length (12 Volts)

Notes:

- The specified wire length is for a pair of conductors from the solar, load or battery source to the controller (1-way distance).
- Figures are in meters (m) and feet (ft).
- For 24 volt systems, multiply the 1-way length in the table by 2.
- For 48 volt systems, multiply the 1-way length in the table by 4.

Ground Connection:

Use the grounding terminal in the wiring compartment to connect a copper wire to an earth ground or similar grounding point. The grounding terminal is identified by the ground symbol shown below that is stamped into the enclosure:



Ground symbol

The minimum size of the copper grounding wire:

• Vetus Solar Charger-45A (SL45) 6 mm ²	(10 AWG)
• Vetus Solar Charger-60A (SL60) 10 mm ²	(8 AWG)

Connect the Power Wires:

First, confirm that the DIP switch #1 is correct for the operating mode intended.

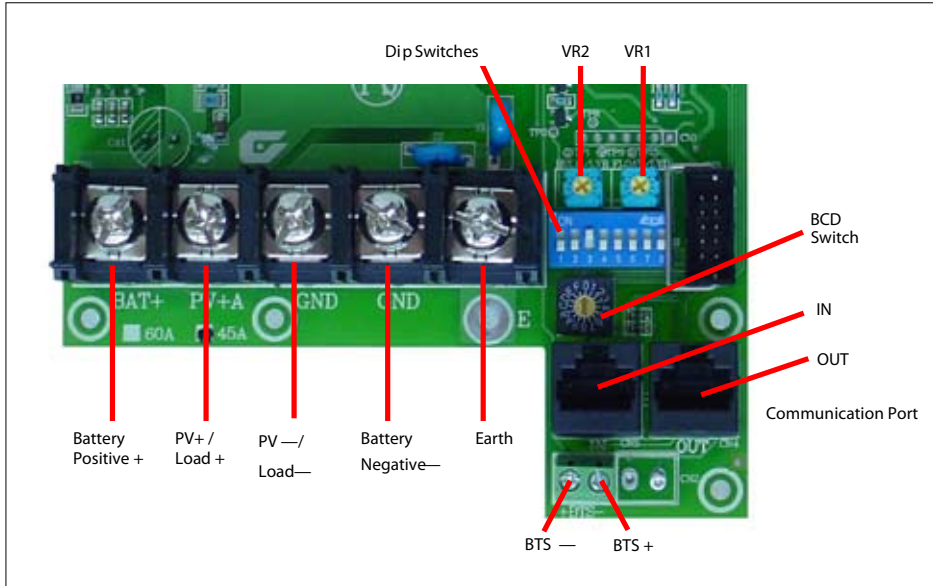

CAUTION: The solar PV array can produce open-circuit voltages over 100 Vdc when in sunlight. Verify that the solar input breaker has been opened (disconnected) before installing the system wires (if the controller is in the solar charging mode).

Using the diagram on the previous pages, connect the four power conductors in the following steps:

1. Confirm that the input and output disconnect switches are both turned off before connecting the power wires to the controller. There are no disconnect switches inside the Vetus Solar Charger.
2. Pull the wires into the wiring compartment. The Battery Temperature Sensor (BTS) wires can be inside the conduit with the power conductors.
3. Connect the Battery + (positive) wire to the Battery + terminal.
4. Connect the Battery - (negative) wire to the Battery - terminal.
5. Connect the Solar + wire (positive) to the Solar + terminal. (or Load + / Diversion +)

6. Connect the Solar – (negative) wire to the Solar – terminal. (or Load – / Diversion –)

The CE certification requires that the battery conductors and BTS wires shall not be accessible without the use of a tool and are protected in the battery compartment.

Do not bend the power wires up toward the access cover. These large wires can damage the meter assembly when the access cover is attached to the controller.

Torque each of the five power terminals to 6 Nm (50 in-lbs).

Power-Up

- Confirm that the solar (or load) and battery polarities are correct.
- Turn the battery disconnect on first. Observe the LED's and LCD meter to confirm a successful start-up.
- Note that a battery must be connected to the Vetus Solar Charger to start and operate the controller. The controller will not operate from a solar input only.
- Turn the solar (or load) disconnect on.

2.4.7 Finish Installation

Inspect for tools and loose wires that may have been left inside the enclosure.

Check the power conductors to make sure they are located in the lower part of the wiring compartment and will not interfere with the cover and the LCD meter assembly.

NOTE: If the power conductors are bent upwards and touch the LCD meter assembly, pressing the cover down on the wires can damage the meter.

- Carefully place the cover back on the controller and install the one cover screw.
- Closely observe the system behaviour and battery charging for 2 to 4 weeks to confirm the installation is correct and the system is operating as expected.

2.5 Communication with the Vetus Combi-Gamma

Vetus Solar Charger Series can not only operate alone when the BCD Switch is placed at 0 but also communicate with Vetus Combi-Gamma up to 10 units together when BCD Switch is placed at 1~A. The example of how to wire 1 unit of the Vetus Solar Charger and how to wire 2~10 units to Vetus Combi-Gamma is demonstrated in the following.

The Wiring of 1 Unit of Vetus Solar Charger to Communicate with Vetus Combi-Gamma

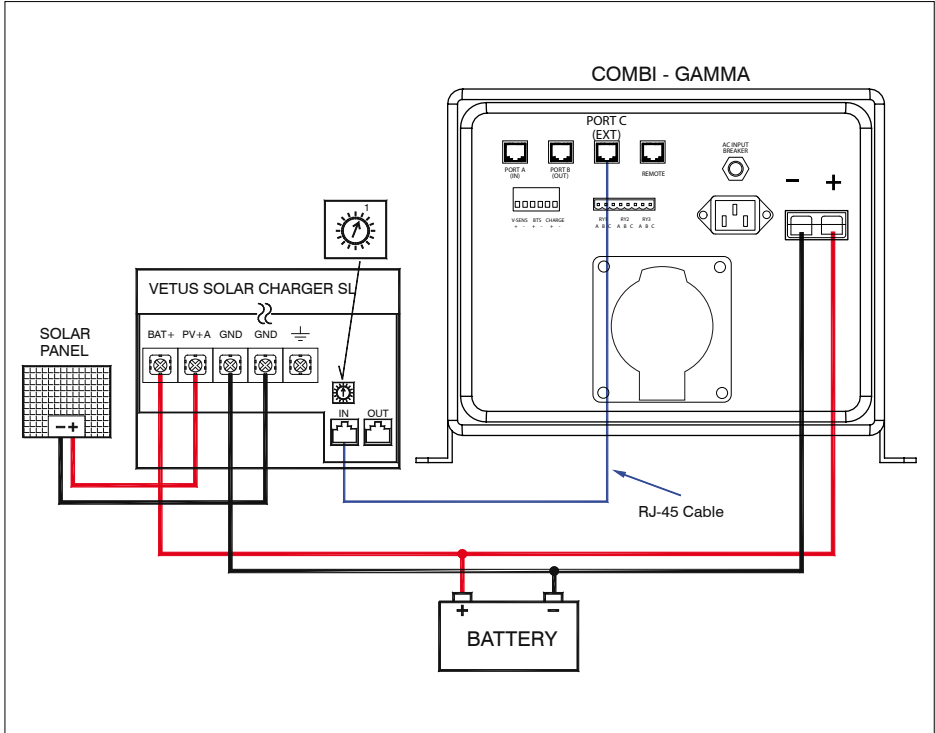

The Wiring of 2~10 units of Vetus Solar Charger to Communicate with Vetus Combi-Gamma

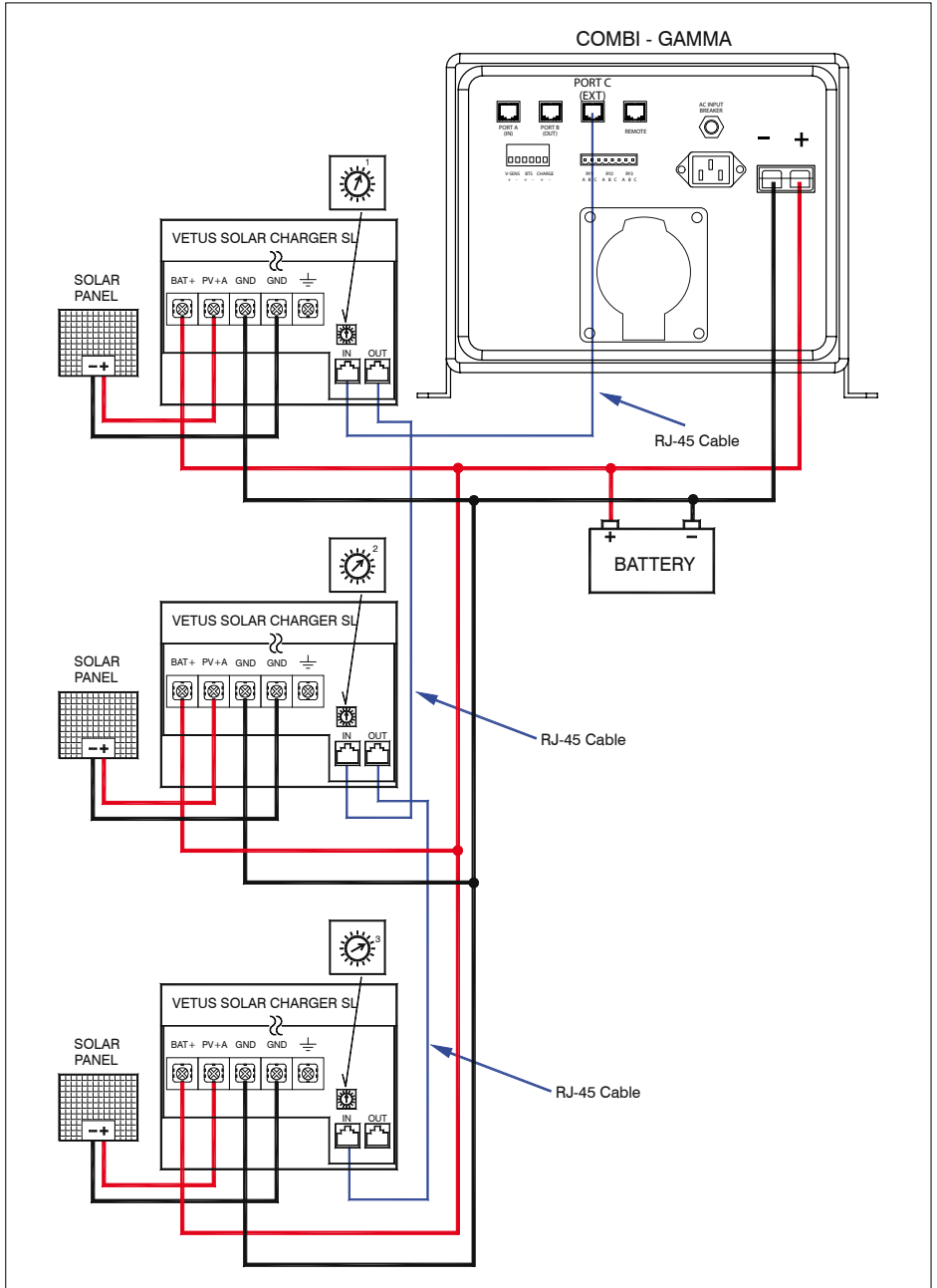

3 Front Cover Operation

There are 4 LEDs, 1 LCD Meter of 16 x 2 characters and 2 push buttons on Vetus Solar Charger front cover. The details are described as follows:



3.1 LED Status Indicators

Four LED indicate operating status of the controller. When the controller is in Charge Control Mode (or Diversion Charge Control Mode), the charge mode (green) LED will blink. When in Load Control Mode, the Load Control Mode (red) LED will blink. When battery equalization is in process, the Equalization (orange) LED is blinking. A red LED solid or blinking indicates a fault condition.

3.2 Charge Control or Diversion Control Mode Indications

“Charge Mode LED” Solid Green:

The battery is being charged in the FLOAT stage. The status LED remains ON solid unless the batteries drop below the float voltage setting for an accumulative period of one hour. This allows the user to confirm that the system reached the float stage during the charging process when checked at the end of the day. Reaching the float stage frequently is a good indication of proper system operation and will maximize battery life and performance.

“Charge Mode LED” Blinking Green:

The controller is CHARGE CONTROL or DIVERSION CONTROL Mode and the battery is not fully charged. As the battery voltage approaches the BULK setting, the status LED will blink green several times (up to five) and then pause, indicating the battery voltage is approaching the BULK setting and provides an indication of the battery condition. Refer to the table 1 to determine the battery voltage.

NOTE: A single green flash indicates the battery is below the bulk voltage setting. It does NOT indicate the batteries are charging.

Battery Voltage (Using LED Status Indicator)			
LED Status	Green LED (Charge/Diversion Mode)		
Always ON	Battery at FLOAT setting		
5 Blinks	Battery at BULK setting		
Bulk Setting Minus (-)			
4 Blinks	0.25 VDC	0.50 VDC	1.00 VDC
3 Blinks	0.50 VDC	1.00 VDC	2.00 VDC
2 Blinks	0.75 VDC	1.50 VDC	3.00 VDC
1 Blinks	> 0.75 VDC Below Bulk	> 1.50 VDC Below Bulk	> 3.00 VDC Below Bulk
DC Voltage	12 Volts	24 Volts	48 Volts

3.3 Load Control Indicators

“Load Control Mode LED” Solid Red:

The controller is in DC Load Control Mode and the battery voltage has reached the Low Voltage Disconnect (LVD) setting. After a 6-minute delay, DC loads will be disconnected unless the user reduces the load to a point that the battery voltage exceeds the LVD setting.

“Load Control Mode LED” Blinking Red:

As battery voltage approaches the LVD setting, the LED will blink red several times (up to five) and then pause providing an indication of battery voltage. Refer to Table 2 to determine the battery voltage.

Battery Voltage (Using LED Status Indicator)			
LED Status	Red LED (Load Control Mode)		
Always ON	Battery at LVD setting (for 6 minute=LVD)		
5 Blinks	>0.15 Above LVD	>0.3 Above LVD	>0.45 Above LVD
LVD Setting Plus (+)	0,15 VDC	0,30 VDC	0,45 VDC
4 Blinks	0.15 VDC	0.30 VDC	0.45 VDC
3 Blinks	0.30 VDC	0.60 VDC	0.90 VDC
2 Blinks	0.45 VDC	0.90 VDC	1.35 VDC
1 Blinks	> 0.45 VDC Above LVD	> 0.90 VDC Above LVD	> 1.35 VDC Above LVD
DC Voltage	12 Volts	24 Volts	48 Volts

Table 2 Battery Voltage LED Indication (Load Control Mode)

“Load Control Mode LED” Slow Blinking Red:

The controller is in the DC Load Control Mode and has disconnected the loads due to reaching the LVD setting. The user can press the reset pushbutton for a maximum 6-minute “grace” period when Dip Switch 7 is in OFF position or can wait until the voltage rise above the low voltage Reconnect (LVR) setting to allow an automatic reset to occur when Dip Switch 7 is in ON position.

3.4 Equalization Mode Indication

“Equalization LED” Blinking Orange:

The controller is in the Equalization Mode. It will automatically stop the equalization process after accumulating setting Equalize Time of operation at Equalize Voltage above the BULK setting. The user can stop the equalization process at any time by pressing the reset push button until the status LED stops.

3.5 Fault Mode Indication

Solid Red:

The controller detects an over-current or an over-temperature condition and the load is disconnected. The controller will try to automatically restart the load after a 10 second delay. If the controller will not restart, turn off all loads and press the reset push button. If it then restarts, the load may be too large. A delay up to five seconds may occur before the controller attempts to restart after pressing the reset push button. The data exchange between CPU and the display panel can be detected a fault by the controller by showing alarm CPF00. When the controller is connected to the Vetus Combi-Gamma, BCD switch position should not be placed at 0 for the communication.

Blinking Red:

In DC Load Control Mode, the controller is in the status of battery low voltage disconnect.

Details of the fault messages could be referred to 3.6.2 Fault Messages.

3.6 LCD Meter Display

This display include a two-line, 32-characters LCD and Four status LED indicator only.

The LCD provides the following information:

- Solar PV Array or DC Load press-through current: 0~80 amps DC
- Battery Voltage: 4 to 80 Volts DC
- Watts: 0 to 3600 Watts (Volts time Amps)
- Amp-hours: 0 to 655536Ah; can be reset to 0
- Totalizing amp-hours: 0 to 65536 Ah; reset to 0 when power is disconnected
- Control mode and battery charging status
- Display of BULK and FLOAT voltage setting value
- Display of Equalization Voltage, Equalization Time and Equalization Interval
- Display of heatsink temperature and BTS temperature
- Fault Messages

3.6.1 LCD Displays Flow

The following chart shows clearly the display flow in the charger/Diversion Control Mode and in the Load Control Mode.

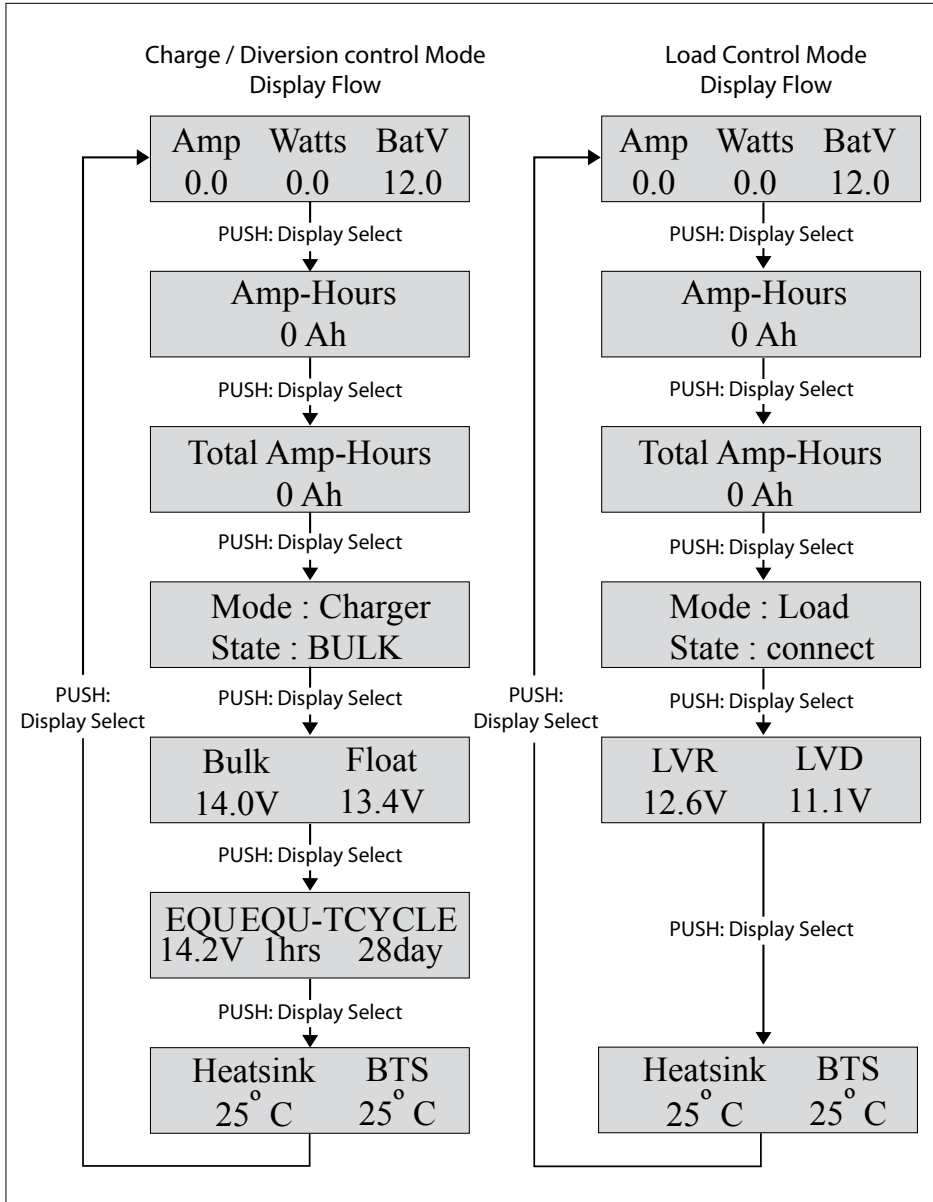

3.6.2 Fault Messages

The LCD displays might have the following fault messages when SunStar stops operating. Refer to their description and causes listed as below in order to remove the faults.

Display	Description	Cause Details
Alarm : OC Over Current	Over Current	The current exceeds 150% of rated current.
Alarm : OT Over Temperature	Heatsink Over Temperature	Heatsink temperature exceeds 90°C
Alarm : LVD Load Disconnect	Battery Low Voltage Disconnect	In Load Control Mode, battery voltage is lower than the setting value for 6 minutes.
Alarm : CPF00 Link Maste Err	Display Panel Error	The CPU is not able to exchange data with the display panel.
Alarm : CPF01 Wait for Combi	Waiting for Combi-Gamma Communication	When BCD switch is placed at either 1~A, Vetus Solar Charger SI is waiting for the communication with Combi-Gamma

4 Solar Battery Charging

4.1 PWM Battery Charging

PWM (Pulse Width Modulation) battery charging is the most efficient and effective method for recharging a battery in a solar system.

Selecting the best method for charging your battery together with a good maintenance program will ensure a healthy battery and long service life. Although the Vetus Solar Charger's battery charging is fully automatic, the following information is important to know for getting the best performance from your Vetus Solar Charger controller and battery.

4.1.1 Four Stages of Solar Charging

- 1. Bulk Charging:** In this stage, the battery will accept all the current provided by the solar system.
- 2. PWM Absorption:** When the battery reaches the regulation voltage, the PWM begins to hold the voltage constant. This is to avoid over-heating and over-gassing the battery. The current will taper down to safe levels as the battery becomes more fully charged.
- 3. Equalization:** Many batteries benefit from a periodic boost charge to stir the electrolyte, level the cell voltages, and complete the chemical reactions.
- 4. Float:** When the battery is fully recharged

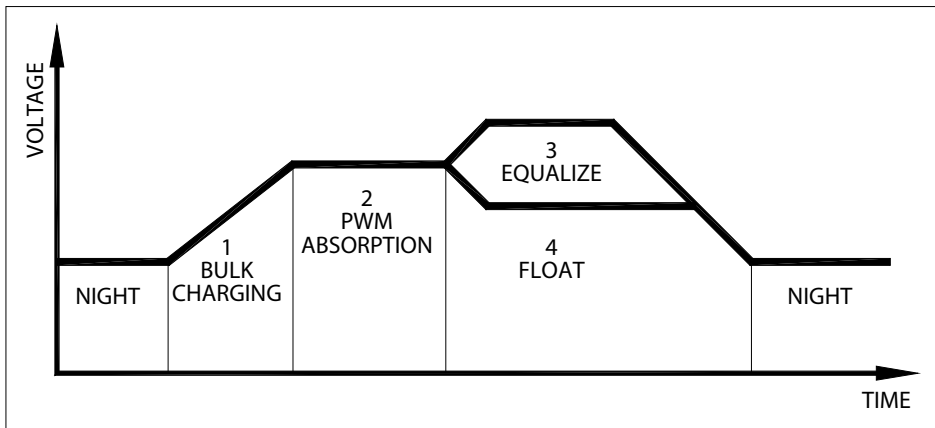

Figure 4.1.1 Solar Charging Stages

4.1.2 Battery Charging Notes

The Vetus Solar Charger manages many different charging conditions and system configurations.

Some useful functions to know follow below.

Solar Overload: Enhanced radiation or “edge of cloud effect” conditions can generate more current than the controller’s rating. The Vetus Solar Charger will reduce this overload up to 130% of rated current by regulating the current to safe levels. If the current from the solar array exceeds 150%, the controller will interrupt charging.

Battery Temperature Compensation: All charging set points are based on 25°C (77°F). If the battery temperature varies by 5°C, the charging will change by 0.15 volts for a 12 volt battery. This is a substantial change in the charging of the battery, and a remote temperature sensor (BTS) is recommended to adjust charging to the actual battery temperature.

Day-Night Detection: The Vetus Solar Charger will automatically detect day and night conditions. Any functions that require measuring time or starting at dawn, for example, will be automatic.

Battery Types: The Vetus Solar Charger’s standard battery charging programs are suitable for a wide range of lead-acid battery types. These standard programs are reviewed in the following Section 4.2. A general review of battery types and their charging needs is provided in Section 8.0.

4.2 Standard Battery Charging Programs

The Vetus Solar Charger provides 8 standard battery charging algorithms (programs) that are selected with the DIP switches. These standard algorithms are suitable for lead-acid batteries ranging from sealed (gel, AGM, maintenance free) to flooded to L-16 cells and Ni-cad etc. In addition, an 8th DIP switch provides for custom set points using the two potentiometer (VR2, VR1)

The table below summarizes the major parameters of the standard charging algorithms. Note that all the voltages are for 12V systems (24V = 2X, 48V = 4X).

All values are 25°C (77°F).

DIP Switches (4-5-6)	A Battery Type	B Bulk Voltage	C Float Voltage	D Equalize Voltage	E Equalize Time (hours)	F Equalize Interval (days)
off-off-off	1 – Sealed	14.0	13.4	None	-	-
off-off-on	2 – Sealed	14.1	13.4	14.2	1	28
off-on-off	3 - Sealed	14.3	13.4	14.4	2	28
off-on-on	4 - Flooded	14.4	13.4	15.1	3	28
on-off-off	5 - Flooded	14.6	13.4	15.3	3	28
on-off-on	6 - Flooded	14.8	13.4	15.3	3	28
on-on-off	7 - L-16	15.0	13.4	15.3	3	14
on-on-on	8-NiCad	16.0	14.5	None	-	-
8-on	Custom	VR2	VR1	VR2+1V	2	7

Table 4.2 Standard Battery Charging Programs

A. Battery Type– These are generic lead-acid and Ni-cad battery types. See Section 8.0 for more information about battery types and appropriate solar charging.

B. BULK Voltage– This is the PWM Absorption stage with constant voltage charging. The “PWM voltage” is the maximum battery voltage that will be held constant. As the battery becomes more charged, the charging current tapers down until the battery is fully charged.

C. Float Voltage– When the battery is fully charged, the charging voltage will be reduced to 13.4 volts for all battery types.

D. Equalization Voltage– During an equalization cycle, the charging voltage will be held constant at this voltage.

E. Equalization Time– The charging at the selected equalization voltage will continue for this number of hours. This may take more than one day to complete.

F. Equalization Interval– Equalizations are typically done once a month. Most of the cycles are 28 days so the equalization will begin on the same day of the month. It can be set by Dip

Switch 4~6 for different interval days. Each new cycle will be reset as the equalization starts so that a setting day period will be maintained.

These 8 standard battery charging algorithms will perform well for the majority of solar systems. However, for systems with specific needs beyond these standard values, any or all of these values can be adjusted using the potentiometers VR2 and VR1.

4.3 Temperature Effects

4.3.1 Battery Temperature Sensor (BTS)

The BTS is used for temperature compensated battery charging. As the battery gets warmer, the gassing increases. As the battery gets colder, it becomes more resistant to charging. Depending on how much the battery temperature varies, it may be important to adjust the charging for temperature changes.

There are three battery charging parameters that are affected by temperature:

PWM Absorption

This is the most important part of charging that is affected by temperature because the charging may go into PWM absorption almost every day. If the battery temperature is colder, the charging will begin to regulate too soon and the battery may not be recharged with a limited solar resource. If the battery temperature rises, the battery may heat and gas too much.

Equalization

A colder battery will lose part of the benefit of the equalization. A warmer battery may heat and gas too much.

Float

Float is less affected by temperature changes, but it may also undercharge or gas too much depending on how much the temperature changes.

The BTS corrects the three charging set points noted above by the following values:

- 12 volt battery: -0.030 volts per $^{\circ}\text{C}$ (-0.017 volts per $^{\circ}\text{F}$)
- 24 volt battery: -0.060 volts per $^{\circ}\text{C}$ (-0.033 volts per $^{\circ}\text{F}$)
- 48 volt battery: -0.120 volts per $^{\circ}\text{C}$ (-0.067 volts per $^{\circ}\text{F}$)

Variations in battery temperature can affect charging, battery capacity, and battery life. The greater the range of battery temperatures, the greater the impact on the battery. For example, if the temperature falls to 10°C (50°F) this 15°C (27°F) change in temperature will change the PWM, equalization and float set points by 1.80V in a 48V system.

Temperature	12 Volt	24 Volt	48 Volt
50°C / 122°F	- 0.75 V	- 1.50 V	- 3.00 V
45°C / 113°F	- 0.60 V	- 1.20 V	- 2.40 V
40°C / 104°F	- 0.45 V	- 0.90 V	- 1.80 V
35°C / 95°F	- 0.30 V	- 0.60 V	- 1.20 V
30°C / 86°F	- 0.15 V	- 0.30 V	- 0.60 V
25°C / 77°F	0 V	0 V	0 V
20°C / 68°F	+ 0.15 V	+ 0.30 V	+ 0.60 V
15°C / 59°F	+ 0.30 V	+ 0.60 V	+ 1.20 V
10°C / 50°F	+ 0.45 V	+ 0.90 V	+ 1.80 V
5°C / 41°F	+ 0.60 V	+ 1.20 V	+ 2.40 V
0°C / 32°F	+ 0.75 V	+ 1.50 V	+ 3.00 V

Table 4.3 Temperature Compensation

The need for temperature compensation depends on the temperature variations, battery type, how the system is used, and other factors. If the battery appears to be gassing too much or not charging enough, an BTS can be added at any time after the system has been installed.

The Vetus Solar Charger will recognize the BTS when the controller is started (powered-up).

4.4 Equalization

Routine equalization cycles are often vital to the performance and life of a battery — particularly in a solar system. During battery discharge, sulphuric acid is consumed and soft lead sulphate crystals form on the plates. If the battery remains in a partially discharged condition, the soft crystals will turn into hard crystals over time. This process, called “lead sulphation,” causes the crystals to become harder over time and more difficult to convert back to soft active materials.

Sulphation from chronic undercharging of the battery is the leading cause of battery failures in solar systems. In addition to reducing the battery capacity, sulfate build-up is the most common cause of buckling plates and cracked grids. Deep cycle batteries are particularly susceptible to lead sulphation.

Normal charging of the battery can convert the sulphate back to the soft active material if the battery is fully recharged. However, a solar battery is seldom completely recharged, so the soft lead sulphate crystals harden over a period of time. Only a long controlled overcharge, or equalization, at a higher voltage can reverse the hardening sulphate crystals.

In addition to slowing or preventing lead sulphation, there are also other benefits from equalizations of the solar system battery. These include:

Balance the individual cell voltages.

Over time, individual cell voltages can drift apart due to slight differences in the cells. For example, in a 12 cell (24V) battery, one cell is less efficient in recharging to a final battery voltage of 28.8 volts (2.4V/c). Over time, that cell only reaches 1.85 volts, while the other 11 cells charge to 2.45 volts per cell. The overall battery voltage is 28.8V, but the individual cells are higher or lower due to cell drift. Equalization cycles help to bring all the cells to the same voltage.

Mix the electrolyte.

In flooded batteries, especially tall cells, the heavier acid will fall to the bottom of the cell over time. This stratification of the electrolyte causes loss of capacity and corrosion of the lower portion of the plates. Gassing of the electrolyte from a controlled overcharging (equalization) will stir and remix the acid into the battery electrolyte.

NOTE: Excessive overcharging and gassing too vigorously can damage the battery plates and cause shedding of active material from the plates. An equalization that is too high or for too long can be damaging. Review the requirements for the particular battery being used in your system.

4.4.1 Standard Equalization Programs

Both automatic and manual equalizations can be performed using either the standard charging programs or a custom setting.

Manual Equalization

The Vetus Solar Charger is shipped with the DIP switch set for manual equalization only. This is to avoid an unexpected or unwanted automatic equalization. In the manual mode, the push button is used to both start and stop a manual equalization. Hold the push button down for 5 seconds to start or stop an equalization (depending on whether an equalization is in progress or not).

There are no limits to how many times the push button can be used to start and stop equalizations. Equalizations will be terminated automatically per the charging program selected if the push button is not used to manually stop the equalization.

Automatic Equalization

If the equalization DIP switch is moved to the ON position, the equalizations will begin automatically per the charging program selected. Other than starting, the automatic and manual equalizations are the same and follow the standard charging program selected. The push button can be used to start and stop equalizations in both the manual and automatic mode.

4.4.2 Typical Equalizations

The automatic equalizations will occur at the selected charging program from Dip Switch 4~6. When equalization begins (auto or manual), the battery charging voltage increases up to the equalization voltage (Veq). The battery will remain at Veq for the time specified in the selected charging program.

The equalization process will continue until the voltage has been held above the bulk setting for a cumulate period of two hours. A second manual equalization cycle can be started with the push button if needed.

If the equalization cannot be completed in one day, it will continue the next day or days until finished. After an equalization is completed, charging will return to PWM absorption.

4.4.3 When to Equalize

The ideal frequency of equalizations depends on the battery type (lead-calcium, lead-antimony, etc.), the depth of discharging, battery age, temperature, and other factors.

One very broad guide is to equalize flooded batteries every 1 to 3 months or every 5 to 10 deep discharges. Some batteries, such as the L-16 group, will need more frequent equalizations.

The difference between the highest cell and lowest cell in a battery can also indicate the need for equalization. Either the specific gravity or the cell voltage can be measured. The battery manufacturer can recommend the specific gravity or voltage values for your particular battery.

4.5 Float

When a battery becomes fully charged, dropping down to the float stage will provide a very low rate of maintenance charging while reducing the heating and gassing of a fully charged battery. When the battery is fully recharged, there can be no more chemical reactions and all the charging current is turned into heat and gassing.

The purpose of float is to protect the battery from long-term overcharge. From the PWM absorption stage, charging is dropped to the float voltage. This is typically 13.4V.

5 Load Control

This section describes the user selectable load control settings (5.1) and the low voltage load disconnect (LVD) warning indications (5.2). Load information and general cautions are provided in the remaining sections.

5.1 Load Control Settings

The primary purpose of a low voltage load disconnect function (LVD) is to protect the system battery from deep discharges that could damage the battery.

In the Load Control mode, the Vetus Solar Charger provides for eight standard LVD settings that are selected by the DIP switches. These are described in the table below. Custom LVD settings are possible using two potentiometers (VR2, VR1).

DIP Switches	12V LVD	24V LVD	48V LVD	Battery SOC%	12V LVR	24V LVR	48V LVR
off-off-off	11.1	22.2	44.4	8	12.6	25.2	50.4
off-off-on	11.3	22.6	45.2	12	12.8	25.6	51.2
off-on-off	11.5	23.0	46.0	18	13.0	26.0	52.0
off-on-on	11.7	23.4	46.8	23	13.2	26.4	52.8
on-off-off	11.9	23.8	47.6	35	13.4	26.8	53.6
on-off-on	12.1	24.2	48.4	55	13.6	27.2	54.4
on-on-off	12.3	24.6	49.2	75	13.8	27.6	55.2
on-on-on	10.5	21.0	42.0	4	12.0	24.0	48.0
8-on	VR1 Setting			VR2 Setting	VR2-installing		

Table 5.1 Standard Control Load Programs

The table above describes the standard selectable LVD battery voltages for 12, 24 and 48 volt systems. The LVR values are the load reconnect set points. The "Battery SOC %" provides a general battery state-of-charge figure for each LVD setting. The actual battery SOC can vary considerably depending on the battery condition, discharge rates, and other specifics of the system.

5.1 Inductive Loads (Motors)

For DC motors and other inductive loads, it is strongly recommended to install a diode near the controller. Inductive loads can generate large voltage spikes that might damage the controller's lightning protection devices.

The diode should be installed near the controller, and in the orientation shown in the diagram on the below:

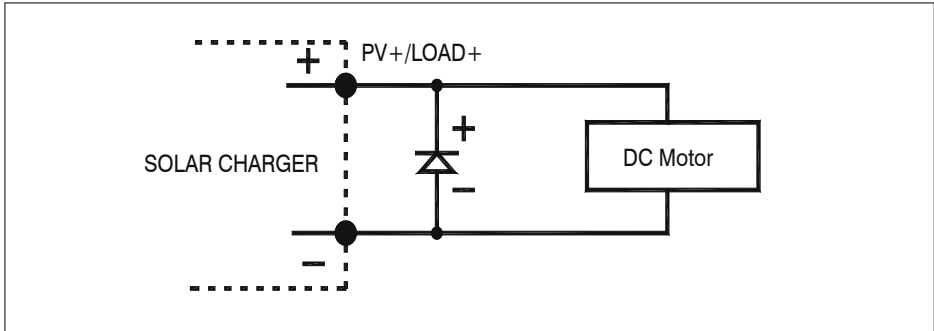

The specifications for the diode follow:

- a power diode
- rated equal or greater than 80 volts
- rated equal or greater than 45 amps (SL45) or 60 amps (SL60)

For large inductive loads, a heat sink for the diode may be necessary.

5.2 General Load Control Notes

In addition to the inductive loads discussed above, there are a few other load issues that require attention:

5.2.1 Inverters

Inverters should never be connected to the Vetus Solar Charger.

5.2.2 Parallel Vetus Solar Chargers

Two or more Vetus Solar Chargers should never be put in parallel for a large load. The controllers cannot share the load.

5.2.3 Reverse Polarity

If the battery is correctly connected (LEDs are on), the load should be connected very carefully with regard to polarity (+ / -).

If the polarity is reversed, the controller cannot detect this. There are no indications.

Loads without polarity will not be affected.

Loads with polarity can be damaged. It is possible that the Vetus Solar Charger will go into short circuit protection before the load is damaged. If the LEDs indicate a "Fault", be certain to

check for both shorts and reversed polarity connections.

If the controller does not go into short circuit protection, the loads with polarity will be damaged.

CAUTION: Carefully verify the polarity (+ and –) of the load connections before applying power to the controller.

6 Diversion Charge Control

The Vetus Solar Charger's third mode of operation is diversion load battery charge control. As the battery becomes fully charged, the Vetus Solar Charger will divert excess current from the battery to a dedicated diversion load. This diversion load must be large enough to absorb all the excess energy, but not too large to cause a controller overload condition.

6.1 Diversion Charge Control

In the diversion mode, the Vetus Solar Charger will use PWM charging regulation to divert excess current to an external load. As the battery becomes fully charged, the FET switches are closed for longer periods of time to direct more current to the diversion load.

As the battery charges, the diversion duty cycle will increase. When fully charged, all the source energy will flow into the diversion load if there are no other loads. The generating source is typically a wind or hydro generator. Some solar systems also use diversion to heat water rather than open the solar array and lose the energy.

The most important factor for successful diversion charge control is the correct sizing of the diversion load. If too large, the controller's protections may open the FET switches and stop diverting current from the battery. This condition can damage the battery.

If you are not confident and certain about the installation, a professional installation by your dealer is recommended.

6.2 Diversion Current Ratings

The maximum diversion load current capability for the two Vetus Solar Charger versions is 45 amps (SL45) and 60 amps (SL60). The diversion loads must be sized so that the peak load current cannot exceed these maximum ratings.

6.3 Standard Diversion Battery Charging Programs

The Vetus Solar Charger provides 8 standard diversion charging algorithms (programs) that are selected with the DIP Switches. An user define algorithm (Dip Switch 8 is ON) can be used for custom set points using the two potentiometers, VR2 and VR1.

The table below summarizes the major parameters of the standard diversion battery charging algorithms. Note that all the voltages are for 12V systems (24V = 2X, 48V = 4X).

All values are 25°C (77°F).

DIP Switches (4-5-6)	A Bulk Volt- age	B Float Volt- age	C Equalize Voltage	D Equalize Time (hours)	E Equalize Inter- val (days)
off-off-off	14.0	13.4	None	-	-
off-off-on	14.1	13.4	14.2	1	28
off-on-off	14.3	13.4	14.4	2	28
off-on-on	14.4	13.4	15.1	3	28
on-off-off	14.6	13.4	15.3	3	28
on-off-on	14.8	13.4	15.3	3	28
on-on-off	15.0	13.4	15.3	3	14
on-on-on	16.0	14.5	-	-	-
8-on	VR2	VR1	VR2+1V	2	7

Table 6.3 Standard Diversion Charging Programs

- A. PWM BULK Voltage** - This is the PWM Absorption stage with constant voltage charging. The PWM absorption voltage is the maximum battery voltage that will be held constant.
- B. Float Voltage** - When the battery is fully charged, the charging voltage will be reduced to 13.4 volts for all diversion settings.
- C. Equalization Voltage** - During an equalization cycle, the charging voltage will be held constant at this voltage. Equalizations are manual, and can be selected for automatic.
- D. Equalization Time** - Charging at the selected equalization voltage will continue for this setting number of hours.
- E. Equalization Interval** - Equalizations are typically done once a month cycles can be set in the Equalization Interval in units of days so the equalization will begin according to the setting value. Each new cycle will be reset as the equalization starts.

6.4 Selecting the Diversion Load

It is critical that the diversion load be sized correctly. If the load is too small, it cannot divert enough power from the source (wind, hydro, etc). The battery will continue charging and could be overcharged.

If the diversion load is too large, it will draw more current than the rating of the Vetus Solar Charger. The controller's overload protection may disconnect the diversion load, and this will result in all of the source current going to the battery.

CAUTION: The diversion load must be able to absorb the full power output of the source, but the load must never exceed the current rating of the Vetus Solar Charger controller. Otherwise, the battery can be overcharged and damaged.

6.4.1 Suitable Loads for Diversion

Water heating elements are commonly used for diversion load systems. These heating elements are reliable and widely available. Heating elements are also easy to replace, and the ratings are stable.

NOTE: Do not use light bulbs, motors, or other electrical devices for diversion loads. These loads will fail or cause the Vetus Solar Charger to disconnect the load. Only heating elements should be used.

Water heating elements are typically 120 volts. Elements rated for 12, 24 and 48 volts are also available, but more difficult to source. The derating for 120 volt heating elements is discussed in 6.4.3 below.

6.4.2 Definition of Terms

Maximum Source Current:

This is the maximum current output of all the energy sources (hydro, wind, solar, etc.) added together. This current will be diverted through the Vetus Solar Charger to the diversion load.

Maximum Battery Voltage:

This maximum voltage is the PWM regulation voltage selected with the DIP switches, plus the increase with an equalization, plus the increase due to lower temperatures. The highest battery voltage is commonly 15, 30 and 60 volts for 12-, 24- and 48-volt systems.

Peak Load Current:

At the maximum battery voltage, this is the current the diversion load will draw. This peak load current must not exceed the Vetus Solar Charger's rating.

NOTE: Because the battery can supply any size load, the peak load current is not limited by the source (hydro or wind rating). The diversion load's power rating is the critical specifica-

tion for reliable battery charging.

6.4.3 Load Power Ratings

The power rating of the diversion load will depend on the voltage of the battery being charged. If the heating element is not rated for the same voltage as the diversion system, the power rating of the load must be adjusted to the diversion system's voltage.

The manufacturers typically rate the heating elements for power at a specified voltage. The peak load current at the load's rated voltage will be the power divided by the rated voltage ($I = P / V$). For example: $3000W / 230V = 13$ amps of current.

If the load is being used at a voltage less than the load's rated voltage, the power can be calculated by the ratio of the voltages squared. For example, a 230 volt 2000 watt heating element being used at 60 volts:

$$2000W \times (60/230)^2 = 136 \text{ watts}$$

The 2000W element will only dissipate 136W when being used at 60 volts.

NOTE: The loads (heating elements) can be used at the manufacturer's voltage rating, or at a lower voltage. Do not use the load at a higher voltage than the load's rating.

6.4.4 Maximum Diversion Load

The diversion load should never exceed the Vetus Solar Charger's current rating (45A or 60A). Note that the load is not limited by the source (wind, hydro), and will draw its rated current from the battery.

The following table specifies the absolute maximum diversion loads that can be used with each Vetus Solar Charger version. These loads (heating elements) are rated for the same voltage as the system voltage.

Nominal Voltage	SL45	SL60
48V	2700W at 60V	3600W at 60V
24V	1350W at 30V	1800W at 30V
12V	675W at 15V	900W at 15V

These maximum power ratings are translated to the equivalent at 120 volts resp. 230 V in the following table. If using heating elements rated for 120 volts or 230 V, the power ratings of all the elements can be simply added up and the sum compared with this table and no further math is required.

Nominal Voltage	SL45	SL60
48V	10.8 kW at 120V	14.4kW at 120V
24V	21.6 kW at 120V	28,8 kW at 120V

12V	43.2 kW at 120V	57.6 kW at 120V
48V	39.675 kW at 230V	52.9 kW at 230V
24V	79.35 kW at 230V	105.8 kW at 230V
12V	158.7 kW at 230V	211.6 kW at 230V

To illustrate the same point from the opposite perspective, a heating element rated for 120 volts resp. 230 volts will draw reduced load current as indicated by the following table. A standard 2,000 watt / 120 Vac resp. a 3000 watt / 30 Vac heating element is used as the reference.

Voltage	Power	Current
120V	2000W	16.7A
60V (48V nominal)	500W	8.3A
30V (24V nominal)	125W	4.2A
15V (12V nominal)	31W	2.1A
230V	3000W	13A
60V (48V nominal)	204W	3.4A
30V (24V nominal)	51W	1.7A
15V (12V nominal)	13W	0.9A

Whether using dc rated loads (the first table) or 120V (230V) elements, the total diversion load current must not exceed the current rating of the Vetus Solar Charger.

6.4.5 Minimum Diversion Load

The diversion load must be large enough to divert all the current produced by the source (wind, hydro, etc.). This value is the maximum battery voltage times the maximum source current.

For example, if a hydro source can generate up to 30 amps of current in a nominal 48 volt system (60V maximum), the minimum diversion load size = $60V \times 30A = 1,800$ watts (for loads rated at 60 volts).

General Sizing Example

Consider a 24V system with a wind turbine that is rated to generate 35A of current. A SL45 will not provide the 150% diversion load margin, and the SL45 is only rated for 30A of source current. The SL45 will not provide enough margin for wind gusts and overloads, so a SL60 should be used.

The diversion load should be sized for 52.5A (150% of the source current) up to 60A (the rating

of the SL60). If 55A is selected for the diversion load, the load must be capable of diverting 55A at 30V (maximum battery voltage). If a 30V heating element is used, it would be rated for 1,650 watts (or from 1,575W to 1,800W per the load range noted above).

If a 2,000 watt / 120 volt heating element is used, 13 of these elements in parallel will be required for the diversion load (4.2 amps per element [Table in 6.4.4] x 13 = 54.6 amps).

The minimum diversion load would be the source output (35A) times the voltage (30V). This would require a 1,050 watt heating element rated at 30 volts. Or if a 2,000W heater element rated for 120 volts is used, 9 heater elements will be required to draw the required minimum diversion load at 30 volts.

7 Trouble Shooting

The Vetus Solar Charger performs a continuous self-test to monitor controller and system operation. Detected problems are classified as either faults or alarms. Typically, faults are problems that stop the normal operation of the controller and require immediate attention. Alarms indicate an abnormal condition, but will not stop the controller's operation.

General Troubleshooting

Vetus Solar Charger is not powering up

- Confirm that all circuit breakers and switches in the system are closed
- Check all fuses
- Check for loose wiring connections and wiring continuity
- Verify that the battery voltage is not below 9Vdc
- Verify that the battery power connection is not reversed polarity

The BTS is not working properly

- Check for a reverse polarity connection on the sense leads
- Verify that the BTS connections are wired to the correct terminals
- Check for shorts and continuity in the cables
- Verify that good electrical contact is made at the terminals
- Note that if the Vetus Solar Charger is restarted with a BTS fault present, it will not detect the BTS and the LED indication will stop

Troubleshooting Solar Charging

- Over-charging or under-charging the battery
- DIP switch settings may be wrong
- BTS is not correcting for high or low temperatures
- Over-temperature condition is reducing the charging current (heat sink cooling may be blocked — indicated with LED's)
- Voltage drop between Vetus Solar Charger and battery is too high
- Battery charging requires temperature compensation (connect a Battery Temperature Sensor (BTS)).
- Load is too large and is discharging the battery

Not charging the battery

- DIP switch settings may be wrong (check each switch position carefully)
- Vetus Solar Charger has detected a fault
- Solar circuit breaker or disconnect is open
- Reversed polarity connections at the solar terminals (Vetus Solar Charger will not detect the solar array)
- Short circuit in the solar array has eliminated part of the array output
- Solar array is not providing enough current (low sun or fault in the array)
- Battery is failing and cannot hold a charge

Troubleshooting Load Control

No power to the load

- DIP switch settings may be wrong (check each switch position carefully)
- Controller is in LVD (check the LEDs)
- Load circuit breaker or disconnect may be open
- Check the load cables for continuity and good connection
- An over-temperature condition may have caused the load to be disconnected

Troubleshooting Diversion Control

- Diversion load is too small so PWM reaches 99%
- Diversion load is burned out so PWM reaches 99%
- Diversion load is too large so Vetus Solar Charger faults on over current
- An over temperature condition may have caused the load to be disconnected
- The BTS is not correcting for high or low temperatures
- Voltage drops between the Vetus Solar Charger and battery are too high

8 Battery Information

The standard battery charging programs in the Vetus Solar Charger controller, as described in Section 4.2, are typical charging algorithms for four battery types:

- sealed (VRLA)
- flooded (vented)
- L-16 group
- Nicad and NiFe

Other battery chemistries of special voltages such as 36V, can be charged using a custom charging algorithm modified with the potentiometers VR2 and VR1. Only the standard Vetus Solar Charger battery charging programs will be discussed here.

CAUTION: Never attempt to charge a primary (non-rechargeable) battery.

All charging voltages noted below will be for 12V batteries at 25°C.

8.1 Sealed Batteries

The general class of sealed batteries suitable for solar systems are called VRLA (Valve Regulated Lead-Acid) batteries. The two main characteristics of VRLA batteries are electrolyte immobilization and oxygen recombination. As the battery recharges, gassing is limited and is recombined to minimize the loss of water.

The two types of VRLA batteries most often used in solar are AGM and Gel.

AGM:

Absorbed Glass Mat batteries are still considered to be a “wet cell” because the electrolyte is retained in fibreglass mats between the plates. Some newer AGM battery designs recommend constant voltage charging to 2.45 volts/cell (14.7V). For cycling applications, charging to 14.4V or 14.5V is often recommended.

AGM batteries are better suited to low discharge applications than daily cycling. These batteries should not be equalized since gassing can be vented which causes the battery to dry out. There is also a potential for thermal run-away if the battery gets too hot, and this will destroy the battery. AGM batteries are affected by heat, and can lose 50% of their service life for every 8°C (15°F) over 25°C (77°F).

It is very important not to exceed the gas recombination capabilities of the AGM. The optimum charging temperature range is from 5 to 35°C (40 to 95°F).

Gel:

Gel batteries have characteristics similar to AGM, except a silica additive immobilizes the electrolyte to prevent leakage from the case. And like AGM, it is important to never exceed the manufacturer's maximum charging voltages. Typically, a gel battery is recharged in cycling applications from 14.1V to 14.4V. The gel design is very sensitive to overcharging.

For both AGM and Gel batteries, the goal is for 100% recombination of gasses so that no water is lost from the battery. True equalizations are never done, but a small boost charge may be needed to balance the individual cell voltages.

Other Sealed Batteries:

Automotive and "maintenance-free" batteries are also sealed. However, these are not discussed here because they have very poor lifetimes in solar cycling applications.

NOTE: Consult the battery manufacturer for the recommended solar charging settings for the battery being used.

8.2 Flooded Batteries

Flooded (vented) batteries are preferred for larger cycling solar systems.

The advantages of flooded batteries include:

- ability to add water to the cells
- deep cycle capability
- vigorous recharging and equalization
- long operating life

In cycling applications, flooded batteries benefit from vigorous charging and equalization cycles with significant gassing. Without this gassing, the heavier electrolyte will sink to the bottom of the cell and lead to stratification. This is especially true with tall cells. Hydrocaps can be used to limit the gassing water loss.

Note that a 4% mixture of hydrogen in air is explosive if ignited. Make certain the battery area is well ventilated.

Typical equalization voltages for flooded batteries are from 15.3 volts to 16 volts. However, a solar system is limited to what the solar array can provide. If the equalization voltage is too high, the array I-V curve may go over the "knee" and sharply reduce the charging current.

Lead-Calcium:

Calcium batteries charge at lower voltages (14.2 to 14.4 typically) and have strong advantages in constant voltage or float applications. Water loss can be only 1/10th of antimony cells. However, calcium plates are not as suitable for cycling applications.

Lead-Selenium:

These batteries are similar to calcium with low internal losses and very low water consumption throughout their life. Selenium plates also have poor cycling life.

Lead-Antimony:

Antimony cells are rugged and provide long service life with deep discharge capability. However, these batteries self-discharge much faster and the self-discharging increases up to five times the initial rate as the battery ages. Charging the antimony battery is typically from 14.4V to 15.0V, with a 120% equalization overcharge. While the water loss is low when the battery is new, it will increase by five times over the life of the battery.

There are also combinations of plate chemistries that offer beneficial trade-offs. For example, low antimony and selenium plates can offer fairly good cycling performance, long life, and reduced watering needs.

NOTE: Consult the battery manufacturer for the recommended solar charging settings for the battery being used.

8.3 L-16 Cells

One particular type of flooded battery, the L-16 group, is often used in larger solar systems. The L-16 offers good deep-cycle performance, long life, and low cost.

The L-16 battery has some special charging requirements in a solar system. A study found that nearly half of the L-16 battery capacity can be lost if the regulation voltage is too low and the time between finish-charges is too long. One standard charging program in the Vetus Solar Charger is specifically for L-16 batteries, and it provides for higher charging voltages and more frequent equalizations. Additional equalizations can also be done manually with the pushbutton.

NOTE: The best charging algorithm for flooded, deep-cycle batteries depends on the normal depth-of-discharge, how often the battery is cycled, and the plate chemistry. Consult the battery manufacturer for the recommended solar charging settings for the battery being used.

8.4 Nicad and NiFe Batteries

The Vetus Solar Charger is compatible with Nicad (nickel-cadmium), NiFe (nickel-iron) and alkaline type batteries which must be charged to a higher voltage level to achieve a full charge. When Nicad mode is selected, the equalization process is disabled.



vetus n.v.

FOKKERSTRAAT 571 - 3125 BD SCHIEDAM - HOLLAND - TEL.: +31 10 4377700
TELEFAX: +31 10 4372673 - 4621286 - E-MAIL: sales@vetus.nl - INTERNET: <http://www.vetus.com>

Printed in the Netherlands

090136.02 03-10